

# Station & Rallonges de fourches.



**Ergonomie & Sécurité**



**Rallonges** ouvertes en dessous



**Sécurité** totale

**Fixation automatique** par emboîtement



**Emboîtement** des fourches par glissement.



**Installation et** désinstallation rapide sans descendre du chariot élévateur.

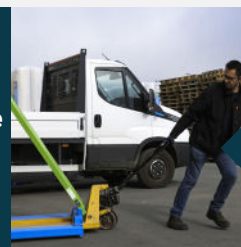

**Station munie de** fourreaux pour un déplacement manuel ou avec chariot élévateur.

## Caractéristiques.

- Conformité totale à la NORME ISO 13284:2022
- Mise en place et dépose rapides sans intervention manuelle
- Fixation par glissement / emboîtement
- Rangement facilité
- Entraxe station 800mm (F)
- Section des fourreaux de la station 170x70 mm
- Innovation brevetée, sélectionnée au concours Lépine
- Adaptation sur-mesure possible

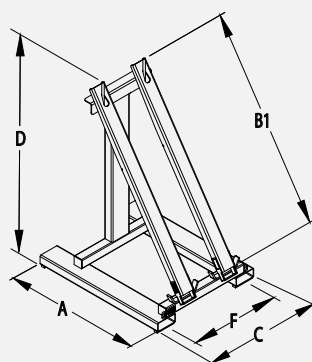

**Norme ISO 13284:2022**

Selon la Norme ISO 13284:2022, la longueur des rallonges doit être conforme à la formule suivante : Longueur maximum des rallonges (B1) = Longueur des fourches d'origine du chariot (B)/0.6

**Attention :** depuis 2022, la norme intègre également d'autres critères tels que la résistance de l'acier. GOUBARD est un des seuls fabricants à proposer des références 100% conformes à la norme ISO 13284:2022.

Références des Stations					Rallonges de Fourches compatibles					
Latéral HT (mm) A.	Largeur frontale HT (mm) C.	Hauteur HT (mm) D.	Poids kg.	Réf. peinte.	Section maxi de vos fourches.	Section int. rallonges.	Longueur (mm) B1.	Poids kg.	Capacité en charge kg Ce.	Réf. peinte (la paire).
1200	980	1490	94	SRF11015	80 x 40	88 x 55	1500	39	1610	FRU08815
					100 x 40	110 x 55	1500	43	1690	FRU11015
1200	980	1665	98	SRF11016	100 x 40	110 x 55	1650	47	1560	FRU11016
1300	980	1885	106	SRF11019	100 x 40	110 x 55	1900	55	1440	FRU11019
					120 x 50	130 x 65	1900	64	1730	FRU13019

# La Station pour manutentionner des charges volumineuses.

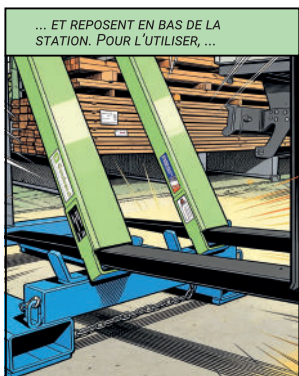
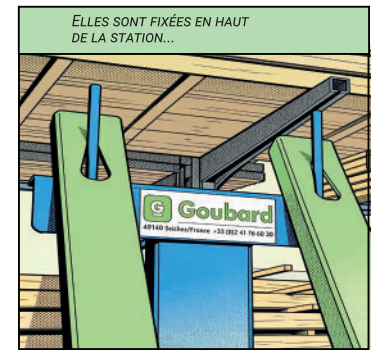
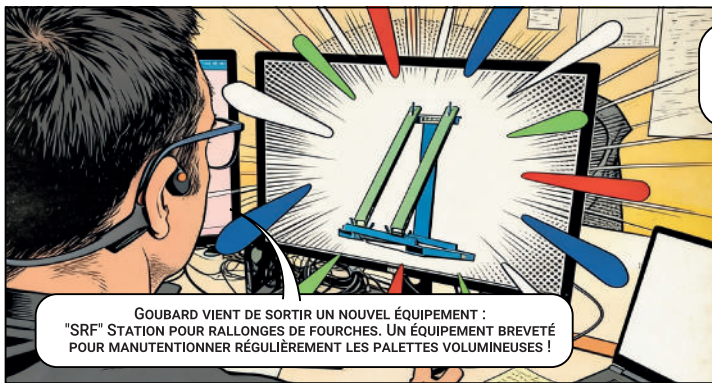
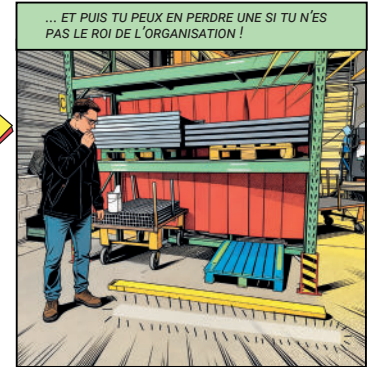
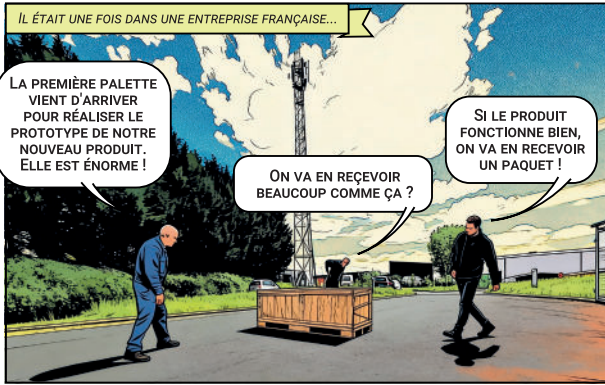

PRODUCTION : GOUBARD - ACTEURS : MARTINE, CHRISTOPHE, JÉRÉMY, WILLY, JÉRÉMIE, MATHIEU & DOMINIQUE RÉCIT & RÉALISATION : DOLCE VOLA